



Follow us    

60 PAYA LEBAR ROAD, #10-28
PAYA LEBAR SQUARE, SINGAPORE 409051
Tel: 6977 9652 | Web: www.ssia.org.sg



Now available on
Magzter Digital
Magazine Store

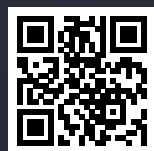

Singapore
Semiconductor Voice:
www.ssia.org.sg/voice



www.ssia.org.sg
PRICE: \$6.00

TOGETHER... TOWARDS
A SUSTAINABLE ECOSYSTEM

Semiconductor Women's Forum 2022

THURSDAY, 10 MARCH

Making a Difference – Towards an
Inclusive and Sustainable Ecosystem

Find out how you can support
and be a part of this event

secretariat@ssia.org.sg

EVENT DETAILS:



FOREWORD BY Executive Director

First and foremost, a happy new year to all our readers, followers, partners and friends.

Our first edition of VOICE in 2022 essentially depicts SSIA's priorities for the new year and beyond. We wrapped up 2021 unveiling our work streams - **growing and developing our workforce, strengthening and growing our local ecosystem, and SUSTAINABILITY.**

The last word in itself contains so many interpretations – beyond the most intuitive and traditional definition. Why do we need to grow and develop our workforce? Why have we not stopped strengthening and growing our local ecosystem? Surely, we want to keep our businesses sustainable. Considering the fact that manufacturing is one of the most energy-intensive sectors, environmental sustainability must also be a growing concern among us – if not with best practices already set in motion, by some.

SSIA took about three years to reset, reboot and recharge – when I came onboard. We are more than ready now to take bigger leaps and deeper dives into addressing existing and new needs of our industry, partners and Singapore at large.

Of which, the talent crunch remains top of mind. With about 2000 jobs expected to be created in the next three to five years in our sector, the question on our minds must be – where do we find these talents? Are there mid-career switchers who are one step short of stepping into new terrains? Can we steer the younger generation towards us as their career of choice, even before they decide their tertiary academic choice?

SSIA's first of four annual flagship events for the year – **Electronics Industry Day** is ready to roll from 20 January and is our touchpoint to tackle the abovementioned. If I may say, 2022's EID is not just an event in a day – we have scaled it up to include a whole series of online and onsite activities, from exhibitions, career fairs, talks, visits, through to March - that we are inclined to rebrand it.

We are privileged that Mr Alvin Tan, Minister of State for Ministry of Trade and Industry and Ministry of Culture, Community and Youth is gracing the event as Guest of Honour once again. Mr Alvin Tan is a strong advocate of our causes that resonate with him. Co-organised with JTC, and supported by e2i, EDB, MINDEF and WSG, in addition to more than ten academic institutions and almost forty industry partners, I am heartened that we are indeed together in this, towards a sustainable, better, stronger ecosystem.

Will an event – even one that lasts three months – resolve our challenge? Absolutely not. We remain resolute in this ongoing exercise, and we need your support and involvement to complete the mission with us. You know I will not hesitate to seek your help, neither will I stop seeking your help. The year has only just begun – there will be many more opportunities for us to collaborate.

Not forgetting, opportunities to meet soon, I hope. For now, an early Chinese New Year greeting to all. Stay safe and see you soon!

Best regards
Wee Seng

EDITORIAL TEAM

**EXECUTIVE
DIRECTOR**
Ang Wee Seng
weeseng@ssia.org.sg

**STRATEGIC
PROGRAMS
DIRECTOR**
Julie Koh
juliekoh@ssia.org.sg

**DEPUTY DIRECTOR
OF PROJECTS**
Daphne Leong
daphne@ssia.org.sg

**COMMUNICATIONS
MANAGER**
Lynda Lim
lyndalim@ssia.org.sg

HR MANAGER
Patsy Tan
patsy@ssia.org.sg

**SENIOR BUSINESS
DEVELOPMENT
EXECUTIVE**
Jasmine Tai
jasmine@ssia.org.sg

**SENIOR PROJECT
EXECUTIVE**
Rebecca Foo
rebecca@ssia.org.sg

**EXECUTIVE
ASSISTANT**
Cindy Chong
cindy@ssia.org.sg

DESIGNED BY
Superskill Graphics
www.superskill.com

SSIA BOARD

CHAIRMAN
Andrew Chong

VICE-CHAIRMAN
Brian Tan

TREASURER
Jennifer Teong

SECRETARY
Jerome Tjia

BOARD MEMBERS
Chen Seok Ching
Rajan Rajgopal
Soh Lip Leong
Tan Yew Kong
Terence Gan

CONTENTS

03 Foreword by Executive Director and Editorial Team

SSIA UPDATES

06 Electronics Industry Day 2022

08 SSIA Annual General Meeting 2021

13 Competence Centre for Digitalisation, Technology and Innovation (CDTI)

14 Train, Upgrade & Reskill with SSIA

TOGETHER... TOWARDS A SUSTAINABLE ECOSYSTEM

18 Sustainable Solutions for Sustainable Future

20 Realtek Now, Ready for the Future

22 Sustainability for a Future-Proof Industry

26 Building Talent Pool - Attract, Develop, Retain

30 Micron: Powering Sustainable Manufacturing Through Innovation

INDUSTRY

36 Semiconductor Tradewinds - November / December 2021

40 Industrial Transformation ASIA-PACIFIC (ITAP) 2021

43 NTU Prepares Talents for Industry

44 Reshaping Your Supply Chain with Additive Manufacturing Driving Strategic Operations

47 On-Chip Sensor Solution for Indoor Air Quality (IAQ) Monitoring

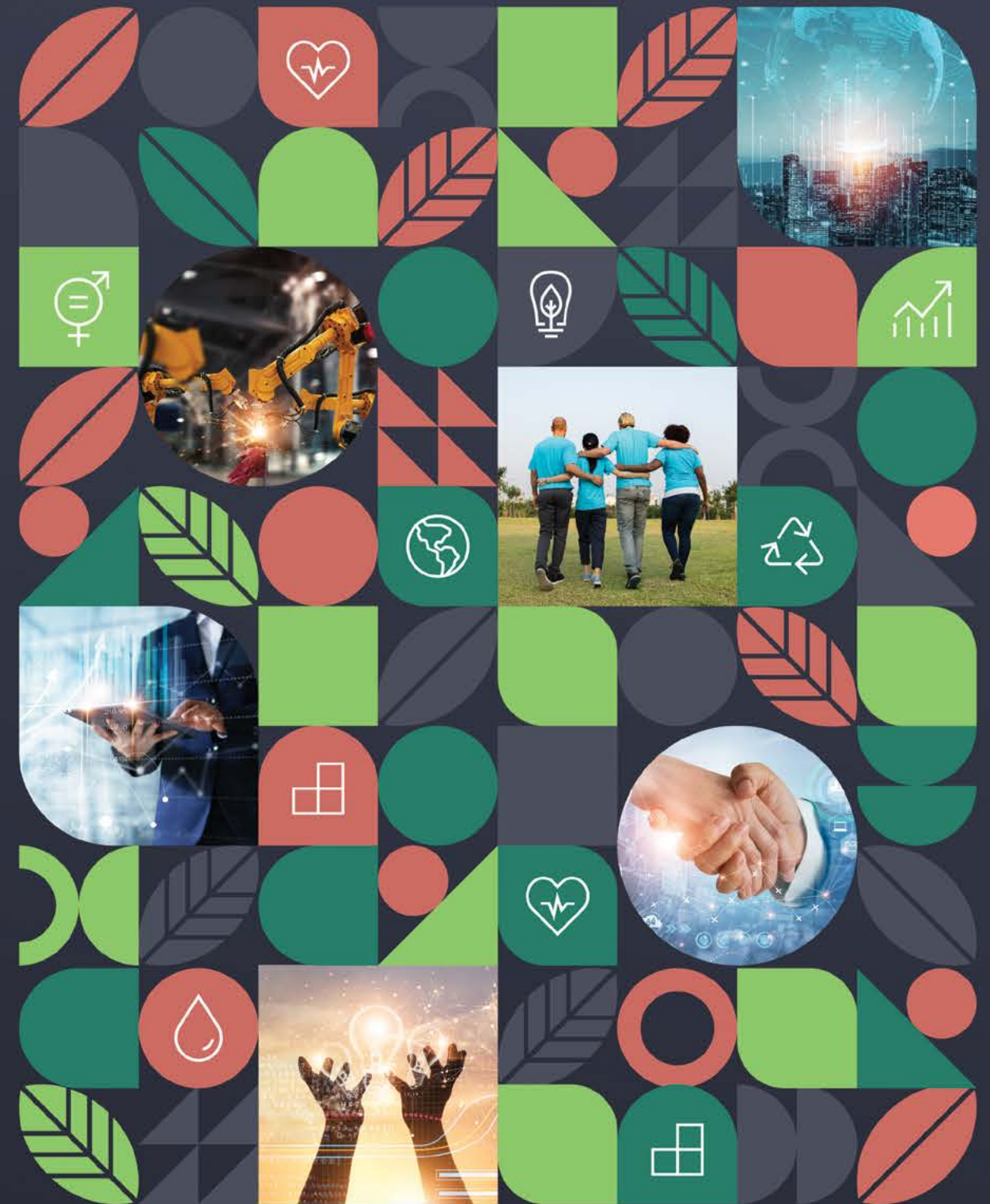

ELECTRONICS INDUSTRY DAY

Thursday, 20 January 2022

Co-organised by SSIA and JTC, the third edition of EID continues to reach out to potential new talents for the semiconductor and electronics sector. A virtual event on Thursday, 20 January 2022 continues with a series of engagements through March 2022, including online and onsite activities such as career fairs, talks, company exhibitions and more!

ORGANISER



CO-ORGANISER



BUILDING INDUSTRIES

Scan for more details



Highlights



VIRTUAL EXHIBITION



CAREER FAIRS



FRINGE ACTIVITIES

SUPPORTING PARTNERS



Air Liquide
AMD
ams OSRAM
Applied Materials
Ardentec
ASM Front-End Manufacturing
ASM Pacific Technology
CEI
Denselight
Disco Hi-Tec Singapore
GlobalFoundries
HP
Institute of Microelectronics

Infineon
Kinergy
KLA
Kulicke & Soffa
Lam Research
Lumileds
MediaTek Singapore
Micron
Microsoft
National Instruments
Panasonic
Razer Inc
Realtek

Rohde & Schwartz
Seagate
Semcorp
Siltronic
Skyworks
Soitec
SSMC
STATS ChipPAC
STMicroelectronics
Swagelok
UTAC
Vanguard
Xilinx



SSIA Annual General Meeting 2021

Wrapping up 2021 on a good note

SSIA convened our secretariat, board and members for a virtual Annual General Meeting on 25 November 2021.



Chairman Andrew Chong addressed the online audience to recap the past year – albeit challenging, the industry had demonstrated our resilience and unity, and brought about breakthroughs in many aspects. Recognising that there is a lot more work to do amid opportunities, he also identified three areas defining SSIA’s priorities and initiatives, namely: growing and developing the workforce, strengthening and growing the local ecosystem, and sustainability. Lastly, he expressed his appreciation for the SSIA team and urged industry partners to continue supporting the association.

Executive Director Ang Wee Seng next dived into more details on initiatives and activities, such as:

A **Semiconductor & Electronics Job Portal** – Soft launched in Q4 2021, this portal has been designed with both jobseekers and employers in mind, promising

better job matching for this industry through an Electronics Placement Accelerator experience. Jobseekers who are keen to be part of a resilient and evolving sector can explore opportunities, while hiring companies can leverage on this self-help digital platform for their placement needs. The portal is also a touchpoint at Electronics Industry Day 2022.

B **Career Conversion Programmes** – Formerly known as Professional Conversion Programmes, SSIA and WSG collaborate on this in support of mid-career jobseekers who are transitioning into new roles within our sector.

C **Singapore Semiconductor Leadership Accelerator (SSLA) Programme** – Supported by EDB, leadership cultivation is another critical component for our industry’s growth and sustainability. Since 2017, this initiative has contributed to the development and growth of more than 100 senior leaders – the most recent edition seeing the largest participation with 30 leaders.

D **SSIA Leadership in Engineering Programme** – Debuted in 2021, this is an initiative targeting young, upcoming leaders, to prime the next generation of successors identified within their companies.

E SSIA will also continue to present our four annual flagship events. Starting with **Electronics Industry Day’s** virtual launch on 20 January 2022 to kickstart a series of fringe activities through to March. The second edition of **Semiconductor Women’s Forum** will also be back, putting the spotlight on a more diverse and inclusive semiconductor industry, followed by **Semiconductor Business Connect** and **SSIA Summit**.



The AGM wrapped up with Treasurer Jennifer Teong sharing financial updates.

Watch our **SSIA At A Glance** video





Intelligence to Light, Passion to Innovation

Together, we make journeys safer and more convenience

Sensing is life

amul OSRAM

How far will you go when you're ready for what's ahead?

Many of today's businesses believe that getting just any cybersecurity solution out there will keep them safe against threats. With hackers preying on companies like a thief in the night, you need a comprehensive security approach to make sure all your endpoints are covered no matter where you are.

Build a stronger defense with comprehensive security

Comprehensive security not only involves coverage. It is a combination of best-of-breed protection, built-in intelligence, and simplified management so you have the freedom to make growth decisions.

SUPREME COVERAGE

Reduce the risk of data breaches and avoid compliance violations—all while boosting your team's productivity. Now, there's an integrated approach to secure your assets like cloud platforms and devices.

BEST-OF-BREED SECURITY

Gain the confidence to digitally transform your business with an end-to-end protection. Microsoft Security is a trailblazer in 5 Gartner Magic Quadrant reports, 8 Forrester™ Wave reports, and excelled in the MITRE Engenuity® ATT&CK® Evaluation.

SMART INTEGRATION AND AI

Get a comprehensive view of the current state of security. Microsoft analyzes 24 trillion security signals so you know exactly where you stand. Native integrations enable automated threat detection and response, remediating up to 97% of all endpoint attacks.

SIMPLICITY AND INTUITIVENESS

Integrate Microsoft security with your existing tools, enabling automation and orchestration capabilities. Now, you can consolidate more than 40 disparate products.



Your comprehensive security starts here

Microsoft Security



You have a vision. We can help you secure it.

Turn possibility into reality with the world's most comprehensive approach to security.





NEW* 163 KALLANG WAY

WORKSPACE FOR THE FUTURE OF YOUR BUSINESS

mapletree industrial



-  Set strategically among global enterprises in the semiconductor industry
-  High specifications and efficient floor plates provides flexibility to accommodate a variety of technical and administrative functions
-  Within 6 minutes' sheltered walk to Geylang Bahru MRT and 3 public bus stop nodes
-  Easy access to recreational sites such as the Sports Hub and Marina Barrage via park connector network

 **CONTACT US TODAY**

LER KIN LOONG
+65 9650 7972
LER.KINLOONG@MAPLETREE.COM.SG

TOH XINYI
+65 9855 3416
TOH.XINYI@MAPLETREE.COM.SG



WWW.MAPLETREE-INDUSTRIAL.COM.SG/KALLANGWAY/

Semiconductor Business Connect Innovation Lab Tour Series

Competence Centre for Digitalisation, Technology and Innovation (CDTI)



On 19 November 2021, SSIA and TUM Asia co-organised a visit for close to 20 industry partners at the Competence Centre for Digitalisation, Technology and Innovation (CDTI) Lab.

skills, as well as to understand digitalisation, RFID System and Smart Sensor implementation possibilities.

The joint training facility between TUM Asia and Festo Didactic conducts technical vocational training for Industry 4.0 automation and digitalisation.



Participants had the opportunity to view setups for various manufacturing systems, such as Pneumatic / Hydraulic Systems, Internet of Things, Sensors, Robotic Handling Systems, as well as a mock up assembly line. The lab offers a glimpse into the hands-on environment for trainees to learn and pick up implementation and handling

One of the most interesting segments of the lab tour was the Augmented Reality (AR) / Visual Reality (VR) experience, where participants got to immerse in the virtual setup. Such technological breakthroughs enable better understanding of equipment and improve troubleshooting as well as setup enhancement.

SSIA will present more relevant and interesting lab and facility tours, under the Semiconductor Business Connect Innovation Lab Tour Series. If your company has facilities that would be of interest to our community, or if you are keen to participate in future runs, contact us at secretariat@ssia.org.sg or follow our social media for updates.

CONTRIBUTED BY



TRAIN, UPGRADE & RESKILL with SSIA

As the semiconductor and electronics sector strengthen our local ecosystem and relook at ways to attract and retain talents, training, up or re-skilling and upgrading remain critical in staying relevant and future-proofing ourselves. Check out programmes in the pipeline, brought to you by SSIA and our learning partners.



INTRODUCTION TO VACUUM AND PLASMA TECHNOLOGY (1 DAY)

Ever wondered how vacuum and plasma systems work? Find out for yourself through this introductory course where you will learn about vacuum and plasma technology commonly applied in the semiconductor, electronic, and manufacturing industries. The knowledge and skills gained through this course can be applied to optical coating, IC chip fabrication, 5G, Internet of Things, and more!



Who is this suitable for?

Engineering and technical personnel interested in understanding the vacuum and plasma systems.



MICROSCOPY AND THIN FILM CHARACTERIZATION FOR FAILURE ANALYSIS (1 DAY)

Ever wondered how imaging and characterisation tools work to provide insights on device failure? Participants of this introductory course will be equipped with fundamental knowledge on microscopy and thin film characterisation for failure analysis. There will also be hands-on opportunities and demonstrations during lesson to facilitate learning.



Who is this suitable for?

Engineering or technical personnel who are interested to learn about microscopy and thin film characterisation tools for failure analysis.



IOT FOR ELECTRONICS INDUSTRY (1 DAY)

This course introduces the fundamentals of Internet of Things (IoT), how data could be transferred from sensors (IoT) to the cloud or network and data management to drive efficiency, enhance and improve operational tasks and work processes for the semicon and electronics manufacturing industry. There would be hands-on session with setting up an IoT system and participants can apply the knowledge and skills to help improve their operational tasks and increase work productivity.

MODULE 1: Overview of a typical IoT application, and sensor data upload to IoT Cloud
MODULE 2: Graphical Data Management Tools and Applications in semicon and electronics manufacturing industries



Who is this suitable for?

All engineering or technical personnel.



INTRODUCTION TO INDUSTRIAL FAILURE MODE AND EFFECTS ANALYSIS (FMEA) (1 DAY)

This course equips participants with the knowledge of Failure Mode and Effects Analysis (FMEA), a step-by-step approach for identifying all possible failures in a design, a manufacturing process, an equipment, or even a service. Participants will also have the opportunity to work on real-life case studies where they will learn how to create a proper risk assessment, prioritise the different critical levels of risk, and trigger necessary mitigation actions.



Who is this suitable for?

Technician, Associate Engineer/Assistant Engineer, Equipment Engineer, Maintenance Engineer.



DATA ANALYTICS FOR ELECTRONICS INDUSTRY (1 DAY)

This course introduces the fundamentals of data analytics and various tools such as data wrangling, data visualisation and data analytics which is one of the enablers of industry 4.0 to improve operational efficiency and business processes. Participants will be equipped with knowledge of fundamentals of data analytics. Participants will also be able to apply these analysis tools to their data when designing and developing their future intelligent systems for the electronics & semiconductor industries. There would be hands-on session with the data analysis tools such as data wrangling, visualisations, regression models and prediction. Participants can apply the knowledge and skills to help improve their operational tasks and increase work productivity.

MODULE 1: Introduction to data analytics and data wrangling
MODULE 2: Data Visualization and Unsupervised Data Analytic Techniques
MODULE 3: Supervised Data Analytic Techniques



Who is this suitable for?

All engineering or technical personnel.

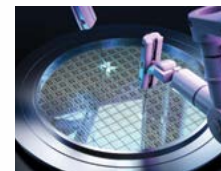

WAFER FABRICATION IN SEMICONDUCTOR INDUSTRY (3 DAYS)

This course provides participants with the relevant knowledge and skills of the Wafer Fabrication process in the Semiconductor Manufacturing Industry. Participants will be introduced to facilities in the manufacturing process such as cleanrooms and handling of hazardous chemicals, various stages in Semiconductor Manufacturing from front end to back end; fabless, manufacturing flow and understanding of the fabrication processes for integrated circuits (IC) and statistical process control. There will be hands-on sessions working with process equipment and metrology tools in the cleanroom. The Industry 4.0 technologies and its benefits to the Semicon Industry will also be taught in the course.



Who is this suitable for?

All engineering or technical personnel under the Electronics Skills framework; associate engineer for process, quality, product, integration, equipment and facility for the Semiconductor & Electronics Industry.



MACHINE VISION AND PATTERN RECOGNITION IN ADVANCED MANUFACTURING (4 DAYS)

This course will cover the application of machine vision and pattern recognition technologies in Advanced Manufacturing. Participants would be instilled with the essential knowledge of machine vision systems including their key components, functionality and the image processing technologies. On top of that, the course will also provide an overview of the techniques in image analysis and the derivation of useful hidden patterns in the images. These would include the selection, development and application of suitable pattern recognition techniques in solving a given problem.



Who is this suitable for?

Engineers, Technology Specialist.



ROBOTICS OPERATION AND ADAPTATION (3 DAYS)

This subject provides the participants with the knowledge and practical skills for them to plan and integrate robotics and automation systems for robot assisted production in advanced manufacturing. Concurrently, techniques for adaptation of industrial robots to meet the requirements of various industrial process control and automation in advanced manufacturing will also be demonstrated.



Who is this suitable for?

Associate Engineer / Technical Support / Machinist / Operator.



SEMICONDUCTOR PROCESSES (2 DAYS)

In today's day and age, semiconductors are found in all aspects of our lives. They control the computers we use to conduct business, the phones and mobile devices we use to communicate, the cars and planes that get us from place to place, the very machines that diagnose and treat illnesses, electronic gadgets we use to listen to music, watch movies, and play games, just to name a few. This course enables learners to gain knowledge of the journey of semiconductor manufacturing from sand to a finished chip. You will also gain an understanding of the local semiconductor ecosystem and how all of us come together to support the sector.

WHY: we need IC chips (more than just computers)

HOW: chips are made (From Sand to a functional chip)

WHAT: are possible areas of involvement (overall eco system)

Who is this suitable for?

Non-technical audience who wants to know a high-level overview of semiconductor devices and how they are fabricated.



Check out [SSIA website](https://www.ssia.org.sg) or scan the QR code for full list of events, training and courses. Or contact Cindy Chong at cindy@ssia.org.sg.



SSIA Welcomes New Members



22, 23, 29 & 30 MARCH
VIRTUAL SESSION

SSIA LEADERSHIP IN ENGINEERING PROGRAMME

Following its debut in 2021, the SSIA Leadership in Engineering Programme will be back in 2022 over a four-day agenda.

Who it's for:

Engineers who have been in the semiconductor and electronics industry for at least 3 years.

Objectives:

To prime the next generation of new leaders for the semiconductor and electronics industry, by helping them develop soft skills and sharpen leadership qualities.

Programme Features:

- ▶ Self reflection and awareness
- ▶ Importance of interpersonal and communication skills at work
- ▶ Interactive workshops with semiconductor and electronics industry case studies and discussions
- ▶ Sharing by industry veterans and leaders
- ▶ Networking with fellow participants from different sectors within the industry... and many more!

For more information, email daphne@ssia.org.sg

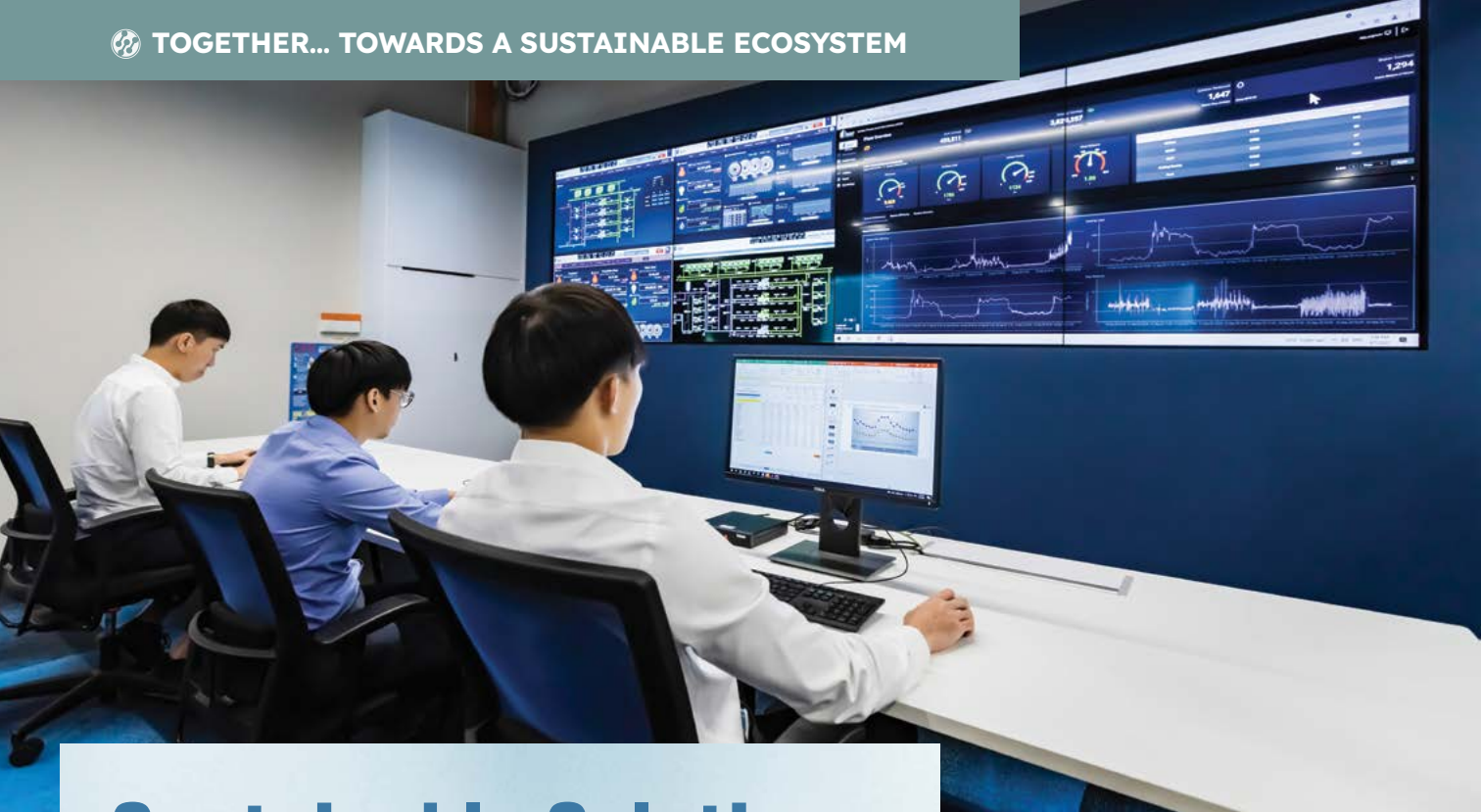

Sustainable Solutions for Sustainable Future

As sustainability becomes the driving force of monumental changes businesses are putting in place, it is crucial for businesses to examine sustainability in a holistic manner where relevant efforts and goals are channelled towards outcomes that not only involve impacting the environment, but also its people and processes. These integrated efforts should be intended to achieve long-term value and longevity for the business.

However, many companies face challenges in doing so due to lack of clarity on suitable mechanism and roadmap in achieving sustainability, or difficulty in determining immediate and long-term action plans. Businesses often find themselves needing to convince various stakeholders that sustainability cannot be addressed on its own like an added module to existing business strategies and development plans. There is clear need for business leaders to establish as early on as possible in this journey, the direct relationship of sustainability, both conceptually and practically, to material value generation.

Sustainability efforts should stem from the core belief that by achieving optimal efficiency in its systems, processes and people, the business will eventually reap guaranteed profits in decades to come, harmonising the

efforts of today for the generations of tomorrow.

The first step in commencing this journey is for businesses to identify discrepancies between their existing strategy and their ultimate sustainable state of operation – where most business leaders find the need for high financial investment and large-scale changes daunting enough to delay or avoid taking real steps towards long-term sustainability. Yet as technology and innovation disrupt the way we do things repeatedly, these daunting pre-requisites for businesses to adopt sustainability-focused solutions are a thing of the past.

REDEFINING SUSTAINABILITY AT BBP

Together with its unique business model, BBP’s innovative offerings are here to redefine the nature and accessibility of sustainable solutions. Sustainable from take up to pre- and post-implementation and for

long-term sustenance. Sustainable with its environmental impact as well as lengthening the returns of each investment dollar of customers’ assets.

BBP’s sustainable solutions aim to set its customers up for guaranteed long-term success in today’s climate where energy usage in buildings continues to rise given improved access to energy in developing countries and rapid growth in global buildings floor area. Global energy usage in buildings makes up over one-third of global final energy consumption and nearly 40% of total direct and indirect CO2 emissions. Cooling specifically, which accounts up to 40% of energy usage in semiconductor facilities and data centres, will be an area of opportunity which businesses can tap on to address their sustainability goals.

BBP is grounded on the belief that achieving optimal efficiencies within its systems, both tangible and intangible, is something to be considered holistically rather than through fragmented piece-meal efforts. Most importantly, to pursue optimizations of its various systems, businesses are given ease of accessibility where they pay minimal to zero fees to achieve optimization.

While such accessibility may sound far-fetched for some, the reality of long-term sustainable businesses is so – it takes nothing more but a business leader who has the vision of future and the conviction to chart sustainable pathways, to embark towards guaranteed success.

SYNERGIZE FOR THE BETTER

With these ambitions for a sustainable future, the work cannot be done solely by the business community. It must be a priority and



a common goal across public and private sectors where governments, trade unions, businesses come together to transform and redefine sustainability ambitions.

One instance is how NEA’s MEES (Minimum Energy Efficiency Standard) regulation has become an opportunity for businesses in Singapore to review its environmental impact. Businesses like Lumileds who have engaged BBP, has successfully achieved continued optimized energy efficiency without experiencing any downtime or major upfront cost more than a decade ago, even before energy efficiency regulation was implemented locally.

Sustainable solutions provider like BBP makes it possible for buildings to achieve optimal energy savings with least possible amount of cost, including corresponding government grants – contributing to a more sustainable ecosystem at large.

Despite so, the government can and must continue to help small and mid-sized businesses to identify suitable actions and relevant available solutions to address their business sustainability gaps, and possibly provide further financial incentives and rebates to motivate bulk of businesses to progress along the adoption spectrum of sustainability driven actions.

ABOUT BBP

BBP is an award-winning energy efficiency company that enables businesses to achieve their carbon neutrality and sustainability goals.

Founded in 2012, BBP has since enabled multiple blue-chip and Fortune 500 companies to achieve up to 40% of energy and cost savings using patented HVAC optimization technologies, Internet of Things (IoT), proprietary software algorithms, Artificial Intelligence (AI) and machine learning.

BBP’s customers pay \$0 to enjoy energy and cost savings. All investment costs associated with implementation and delivery of energy savings solutions are borne by BBP. Cost savings across all sites are independently verified by third party auditors like TUV and DNV.

CONTRIBUTED BY





Realtek Now, Ready for the future

We understand the interplay between business operations and the pulse of the international community. Therefore, we continue to develop sustainability management policies linked to domestic and international standards.

In the IC design industry, the continuation of industrial talents has always been very important, and it is also an important foundation for supporting the sustainable operation of enterprise. In the environmental development, we are striving to strike a balance between products and the environment, so we continue to focus on low-power technologies to reduce the burden on the environment and promote common prosperity.

Talent Development and Corporate Culture

As a member of the knowledge and technology intensive semiconductor IC design industry, human resources and intellectual property are Realtek's most important assets and the cornerstone of the company's development, sustainability, and competitiveness. We have longstanding talent strategies and planning in place that enable us to retain a workforce that can respond to short, mid, and long-term development needs.

Our human resources policy is based on valuing and respecting talent. Safety and happiness are as important as work quality, and are emphasized along with learning and development for better performance. Innovation and service create total value for all.

The Realtek Corporate University offers five academies with different training programs for the continued development and reinforcement of organizational learning and competitiveness. Work and lifestyle improvements include offering our Employee Care Center, which combines various employee welfare benefits to create a friendly environment that promotes organizational action and teamwork.

We also established the Occupational Safety and Health Center for employee care services and environmental testing, in order to build a safe and reliable work environment. We focus on future organizational growth and makes preparations to ensure robust development and innovation.

In 2020, we started construction of the third office in the Hsinchu Science Park to accommodate more employees as the company continued to grow. We recognize that creating an R&D and innovation base, actively developing talent, and building team rapport are at the core of organizational development. We therefore make significant effort in developing human resource management strategies at each level of the organization to ensure talent sustainability.



Contact Us



Reducing Carbon Emissions Through Energy-Saving IC Design

We have long been committed to the design and development of more environmentally friendly and energy-saving IC products. We aim to provide a wide range of total solutions, a large number of which are used in electronic end-products. It is our belief that by continuing to develop innovative ICs with better energy-efficiency, we can help to significantly reduce the carbon emissions worldwide.

We incorporate environmental and energy-saving concepts into the product design process from the start of development for all types of IC products. We reduce unnecessary energy consumption according to use cases, enhance low power product design, and effectively reduce the energy consumption. We are fully committed to providing innovative, highly

effective IC products that meet environmental protection expectations of customers around the world.

Development of Green, Energy-Saving Products.

In 2021, we again successfully developed many next generation products. IoT, BT Audio, and BLE, which are most used in the home market, all have excellent low power consumption. For example, Realtek IoT video SoC - Ameba Pro has been favored by many well-known brands because of Ameba Pro has multi-function, highly integrated and ultra-low power consumption. Ameba Pro integrates all functions into one SoC. Including CPU, memory, ISP, video encoder, dual-band Wi-Fi, audio codec, etc. And highly optimize the power consumption

to provide customers with a high-performance and low-cost hardware platform.

In addition to the sustainable development of industrial talents and the environment. We will continue to introduce more low-power solutions in 2022, which will be used in IoT, BLE, BT Audio, WLAN, NB-IoT, Automotive Ethernet, etc. In the huge data transmission demand generated in the COVID-19 post-epidemic era. Our solutions when used for long periods of time or to send large amounts of data, the significant power savings make the environmental benefits clear. End users appreciate a much better user experience.



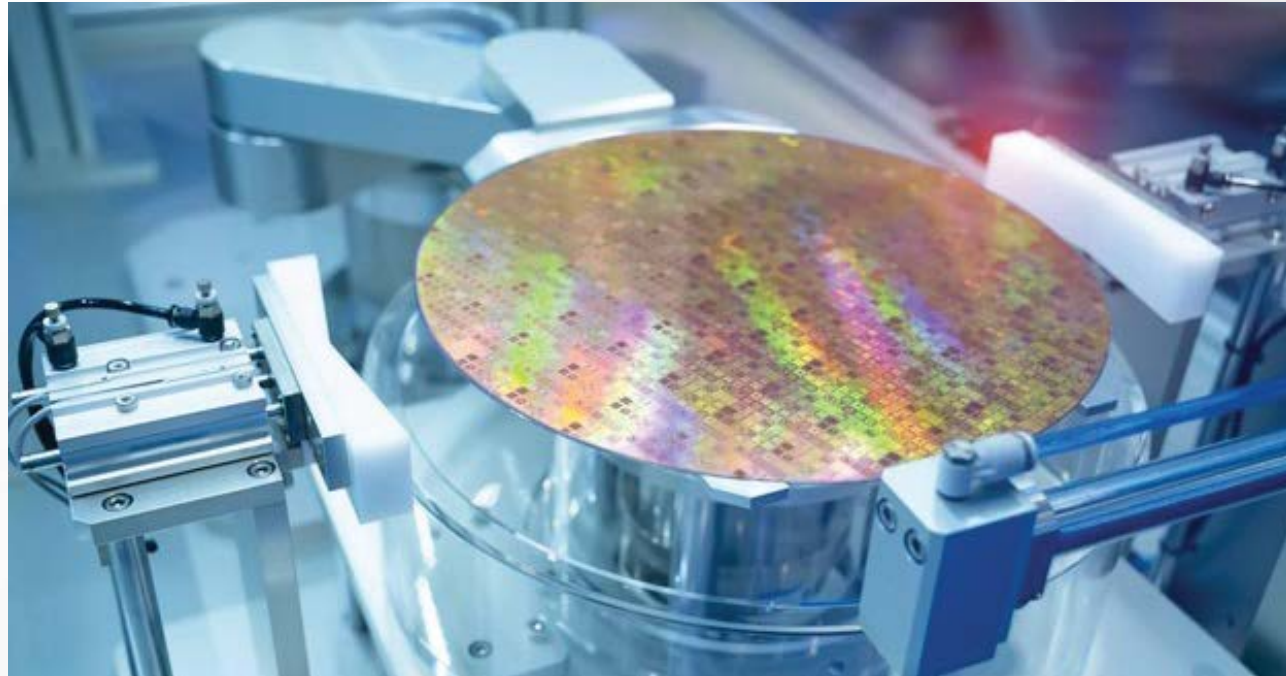

Sustainability for a Future-Proof Industry

Semiconductors are nowadays so ubiquitous that the ability to fabricate them rapidly, efficiently and reliably has recently been the limiting factor in the production capacity of many goods. These include personal computers, phones, cars, connected objects and more, with current supply challenges affecting the likes of GM, Ford, Apple and more. As we transition from an era in which any computer had several users to one in which a single person may own thousands of computers all at once, several questions are raised about the sustainability of the semiconductor industry as a whole: What is its impact on the environment, and how can it be reduced? How can we ensure robust and predictable processes that support sustainable growth for customer markets? Finally, how can answers to these questions be leveraged to address today's struggles to match supply and demand?



Guglielmo Montone & David Meyer, co-founders of Lynceus.ai

These are questions that the team at the Paris-based startup Lynceus are addressing. They deliver an AI-powered model to customers, aimed at anticipating the detection of faulty wafers and providing rapid root cause analysis and corrective action suggestions, ultimately reducing scraps, increasing productivity and efficiency as well as providing visibility over the production line. Working with leading integrated device manufacturers serving the automotive market, Lynceus demonstrated the potential to reduce the time to detect faulty wafers by 90%, correspondingly downsizing the need for measurements by several orders of magnitude. This in turn

has a positive impact on several key aspects of the manufacturing process' sustainability, some of which will be discussed below.

ENVIRONMENTAL SUSTAINABILITY:

Semiconductors can be a powerful tool for sustainability. For instance, used in cars, they can help regulate engine modes and fuel consumption; used in smart-home domestic systems, they can help reduce costs and emissions associated with domestic energy consumption. The same cannot be said of their manufacturing process. Worldwide freshwater use for semiconductor manufacturing is comparable to that of a medium-sized country and, although this issue is currently being addressed through substantial reclamation efforts, each wafer produced, or scrapped, comes at a significant cost of water, energy and raw materials.

The tool provided by Lynceus improves the environmental sustainability of semiconductor manufacturing from a different angle. In addition to increasing the efficiency of the resource usage for each step of the process, substantial benefits can be made by reducing the time to fault detection, inherently reducing the waste of viable wafers and minimizing the environmental cost associated with each individual wafer. For instance, by reducing the time to detect by 90%, the Lynceus platform generates a like-for-like decrease in scraps. Similarly, providing efficient diagnosis tools and faster corrective suggestions can overall increase the consistency and reliability of manufacturing, overall helping reduce excess resource consumption, for example by reducing the need for costly quality

control measurements by up to a four-fold amplitude, although more recent work by Lynceus suggests this reduction could be pushed further up to a twenty-fold reduction in measurements for certain processes.

ECONOMIC SUSTAINABILITY:

As is the case with any other industry, a key driver of manufacturing processes in semiconductors is their economic viability. Beyond the waste of resources, the cost of engineering and the time taken to detect, diagnose and fix issues also cost manufacturers a substantial proportion of their profits.

By providing immediate time to detect, Lynceus can further drive the efficiency of a fab and anticipate any serious incident or diversion that would cause a downstream production restriction. As such, they can also help smooth the fab output and provide visibility on their production - not a small feat when one considers the wide geographical and industrial variety of semiconductor customers. In addition, these reductions also provide visibility for engineers and help smooth workload for employees in fabs. Such tools will provide the means for planification and enable sustainable growth opportunities in most affected markets.

FUTURE-PROOFING THE INDUSTRY:

Driven by current demand far exceeding production capacity, and restrained by the steep buy-in ticket for new fabs and equipment, semiconductor manufacturers have been handed a unique opportunity to redefine sustainability and establish themselves as environmentally conscious, socially responsible and

economically beneficial players. Although substantial capital investments will drive some of the changes to come to meet demand, manufacturers will rely on cycle time reductions and fine-tuned yield enhancement tools to generate tangible returns on investment. In fact, it is now clear that semiconductor manufacturing will be driven to sustainability by the very product being made. Indeed, as chips become more powerful and ubiquitous, complex models and integration within automated control processes will become more affordable and will impact the operational organization of fabs. For instance, with Lynceus, engineers access immediate predictive feedback on wafers being produced as well as automatic feature importance analysis providing failure diagnosis. In turn, they can evaluate product performance and implement corrective actions 90% faster. In parallel, the need for measurements and sampling is reduced by several orders of magnitude, allowing the engineers to focus more time on process-improving changes rather than costly fault monitoring.

In short, semiconductor manufacturing is poised to illustrate a main consequence of the shift to industry 4.0: automation and extensive data collection will allow for efficient and sustainable control of manufacturing processes at each step. This will be helped in no small part by actors such as Lynceus, paving the way for efficiency-driven growth in the years to come.

CONTRIBUTED BY





Cutting-edge
technology is
what creates
our future.

We strive to contribute to the development
of a dream-inspiring society through
our leading-edge technologies and reliable
service and support.

TEL TOKYO ELECTRON

www.tel.com

Building Talent Pool – Attract, Develop, Retain

“An organization is only as strong as the collective talent of the people who work there.” We all heard this before and it is no secret that recruiting and retaining talent are critical to any organization’s success. It is not enough just getting them in the door. This is no longer the endgame; we need to understand what keeps them motivated and engaged. Organizations must be proactive, feel the pulse and be willing to change the game plan.

I interviewed over 50 candidates recently, in preparation for the upcoming Internship Programme as well as the Work-Study Diploma programme. I noticed a common behaviour among the candidates. Branding of the company is important and given as nearly 80% of the candidates questioned their value to the company as well as what learning opportunities are available to facilitate their career growth. Am I surprised? No, as this voice is also consistent with our employees, including myself.

Data is only king if we use it to guide us and transform our decision-making process, in this instance, opportunities to transform our Talent Attraction, Talent Development, and Talent Retention.

One transformation GlobalFoundries is making is in the Internship Programme, where every Intern will get to experience EEE – Experience, Education and Engagement.



Besides working on an assigned project, interns will undergo an enhanced structured programme with curated learning curriculum and meaningful learning objectives.

EXPERIENCE



Every intern is assigned a mentor who will coach the individual throughout the duration of the programme. Besides working on an assigned project, interns will shadow their mentor, attend business meetings and in-fab real-life experience as a technician/engineer apprentice. They will also get to experience our GF culture and values, which are not as obvious currently.

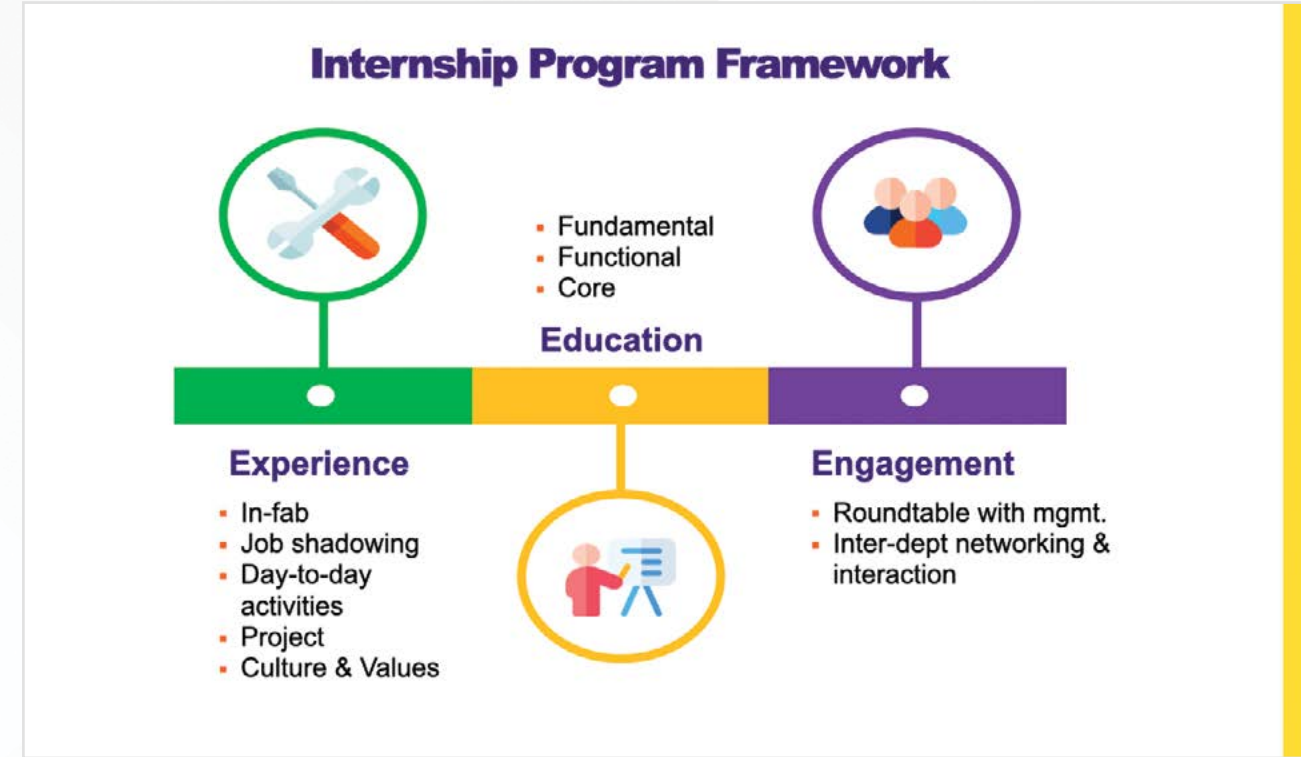

EDUCATION

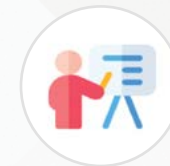

In addition to our Orientation Programme, interns will be exposed to Fundamental, Functional and Core trainings, which are tapped from the Employees Skills Matrix.

- Fundamental - Common generic skills that is needed for all job functions such as Basic Wafer Processing, Statistical Process Control, etc.
- Functional – Specific to assigned job functions.
- Core – Presentation, report writing, critical thinking, diversity & inclusion, etc.

We work in a matrix and always collaborate with colleagues within and outside of our function. Here, we promote and create opportunities for inter-department networking and interaction. There is also a series of engagement with the management team which is a rare opportunity for interns to have true discussions with the leaders of our company and gain perspective on what decisions helped shape their careers.

Internship has come a long way. We need to and must move away from treating them as cheap interim labour. Truly, every intern wants to do meaningful real substantial work in the industry they are working in and should have the opportunity to do so. Interns, just like all employees must be treated equally and given constant nurturing so as to keep them engaged, motivated and provided with learning opportunities to be successful.

Corporately, we believe when providing a positive professional experience to the interns, there will be a higher probability of them staying and landing full-time employment, thriving in the job and adding to GlobalFoundries’ good success stories.



CONTRIBUTED BY

SYLVIA CHAN
Deputy Director
Operations Training &
Development





Intelligence to Light, Passion to Innovation

As ams OSRAM, we create a global leader in optical solutions by providing international industrial capacity in sensor and light technologies at the transformative edge. We add intelligence to light and passion to innovation, enriching our lives. We continuously advance our technologies in **sensing, illumination, and visualization**, while drawing on a century of experience and the ability to serve the full value chain – from emitters to sensors and software.

Sensing is life.



Air Liquide is ACTing for a Sustainable Future!

Since 1902, inventing and shaping the future with state of the art technologies, operational competences and services close to customers or patients, has always been in Air Liquide's DNA. We have been working with our partners and customers in developing new solutions towards a more sustainable future.

Taking Actions for Sustainability through Performance Analytics Centre (PAC)



Our Singapore Performance Analytics Centre (PAC) makes use of predictive data analytics to better understand and manage our Carrier Gas plants. Equipment

reliability is improved, plant uptime is increased and energy consumption is optimized; allowing us to respond more effectively in real time to customers' varying supply needs and reducing the dependency on external gas sources, indirectly lowering carbon emissions.

Reducing carbon footprint of our vehicles



Using data to calculate the consumption rate, the system is triggered to place an order once the tank level hits a certain level and optimizing delivery trips.

Fighting the global warming effects with enScribe™

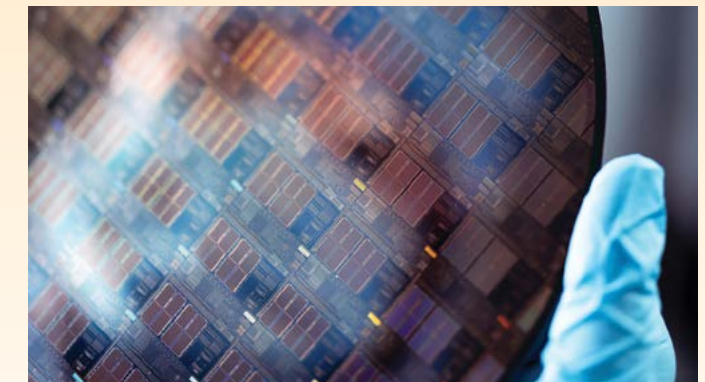

enScribe™ is a new family of advanced etch materials designed for 3D production and able to etch the latest chip architectures very deeply, at a nanometric scale. It is also designed to reduce the Global Warming Potential (GWP) impact typically associated with most contemporary gases used in etch processes.

Scan here to find out more
about Air Liquide Singapore:



Micron: Powering Sustainable Manufacturing Through Innovation

Climate change has become a global priority, and the challenge of protecting and restoring our ecosystems is critical.

In Singapore, the government unveiled the Singapore Green Plan 2030 in February 2021. It charts ambitious targets to catalyze national sustainable development and achieve the long-term net-zero emissions aspiration as soon as viable. While realizing these sustainability goals requires a whole-nation, multiple-stakeholder effort, businesses will play a key role by developing and deploying sustainability solutions. As a pillar of Singapore's economy, the semiconductor industry will be one of the leaders in this transformation journey.

ENVISIONING SUSTAINABILITY

Sustainability at Micron ties directly to the company's vision, mission and values. "As a leading technology company, we are committed to supporting sustainability in all of the places where we operate, and to thinking and acting responsibly for our people and planet," says Kok Sing Chen, corporate vice president and Singapore country manager.

Micron integrates sustainability efforts with a primary focus on responsible operations and sourcing, engaged team members and industry-leading products. By investing US\$1 billion globally over the next five to seven years, Micron

is establishing specific environmental sustainability goals across four key categories: emissions, energy, water and waste.

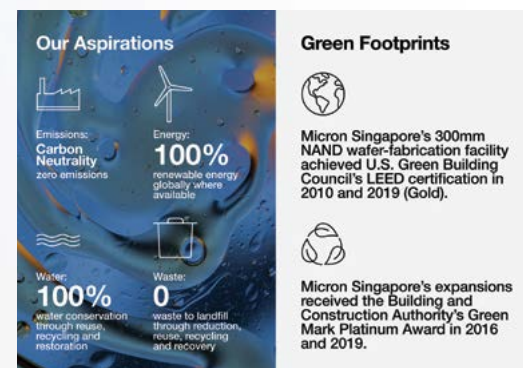

Micron sustainability aspirations and green footprints in Singapore.



Four focused areas of Micron's sustainability strategies.

reducing our carbon footprint," says Chen. Through supplier engagement, technology development and legal compliance, Micron also evaluates new materials to ensure the safety of its team members and products.

Environment-friendly process design

Taking a holistic approach, Micron integrates sustainability into every aspect of its operations, including investments in innovation, new machine learning and artificial intelligence (AI) technologies that improve manufacturing and production efficiencies. With an advanced neural network, the AI team can prevent manufacturing challenges that might cause productivity, materials and energy losses.

ACCELERATING SUSTAINABILITY WITH INNOVATION

Micron strives to make its influence as positive as possible over time through a sustainability strategy that focuses on four areas: product design, process design, infrastructure and operations.

Environment-friendly product design

Memory and storage affect the sustainability of a variety of end products, from computer energy use to vehicle safety, and even the efficiency the company's manufacturing facilities. "Micron's memory and storage solutions are at the core of countless digital devices. We are constantly innovating to make those solutions faster and more efficient, thus

Green infrastructure

Micron Singapore is designated as an Advanced 4th Industrial Revolution Lighthouse by the World Economic Forum's Global Lighthouse Network, a testament to its sustainable commitment. Besides reducing energy consumption, Micron Singapore has installed solar panels on buildings, carparks and available open spaces. The energy produced is equivalent to that needed to power about 6,000 Singapore households for a year. Because manufacturing innovative semiconductor products requires a tremendous amount of water, Micron aspires to achieve 100% water conservation through reuse, recycling and restoration.

Environment-friendly operations

Assessing opportunities to align processes with strategic objectives in early-stage technology development is crucial. A robust network of site-based environmental, health and safety professionals throughout Micron's global operations is equally important for the company to continue reducing its environmental impacts.



Solar panels on the Woodlands carpark, admin building, and CUP building rooftop at the Micron Singapore site were turned on in July 2021.

"Micron is committed to reducing our environmental footprint through recycling initiatives for our operations and partnerships," says Chen. Sludge is an example of recycling waste that Micron Singapore works with suppliers to repurpose into fluoride balls for the steel industry.

COLLABORATING FOR THE COMMUNITY

Since meaningful sustainability encompasses all stakeholders and all opportunities, Micron Singapore has been a long-term partner with

the Singapore government and agencies on sustainability projects that influence not only Micron but also the community. In September 2021, National Parks Board (NParks) announced a Micron donation of \$1 million toward development of the Water Lily Pond in the upcoming Japanese Garden at Jurong Lake Gardens.

"Micron's donation to the Water Lily Pond in Jurong Lake Gardens supports important water conservation that benefits the community," says Chen. The contribution will support the Jurong Lake Gardens' sustainability efforts by implementing a smart water-management system that uses natural vegetation and soil microbes to clean and restore the water within the pond and larger garden.

Chen adds, "We strive to foster a company culture that values a diversity of ideas among our teams and engages our team's passions to best serve the communities where we operate."



Agreement-signing ceremony between (right) Dr. Leong Chee Chiew, executive director of National Parks, Gardens & Nature Reserves Cluster, and (middle) Mr. Chen Kok Sing, corporate vice president and Singapore country manager at Micron, witnessed by (left) Prof. Leo Tan, chairman of the Garden City Fund.





WE ARE THE

INNOVATIVE SOIL

from which smart and energy efficient electronics grow into amazing and sustainable life experiences.



www.soitec.com



Larger Singapore Semiconductor fabs typically having a cooling load of 20,000RT.

A 5% energy-efficiency improvement would save 4800 MWh (or 4.8million kWh) per year. This is significant given the current elevated energy prices and sustainability focus.

Energy savings from maintaining peak heat exchange efficiency – Current methods unable to do so

Chemical treatment with some form of chiller tube cleaning has been the standard for water-cooled chillers.

However, heat insulating minerals will still build up on heat exchange surfaces in the chillers over time due to the working principle of cooling towers and chemicals. Even periodic cleaning of the heat exchange surfaces would do little to help.



To the left is data of a large industrial site in Singapore using NEWater and chemicals for the cooling towers.

The efficiency improves after cleaning, but quickly returns to the poorer levels.

Deston's DCI technology will keep the chiller running at peak efficiency all the time.

Principle: DCI technology directly removes heat-insulating minerals that are generated in the cooling process. This is in contrast with chemical methods delaying the saturation, hence, precipitation of minerals – to a certain limit.

This method not only achieves better energy efficiency, but also simultaneously reduces the amount of water thrown away by up to 80%.

DCI further improved a Green Mark Platinum building's cooling energy efficiency by additional 7.1%

Keppel Bay Tower first to bag Singapore environmental award, Property News -Its annualised energy consumption will be almost half of levels at typical office buildings here.. Read more at straitstimes.com.



Friday, December 11, 2020

Operating Capacity
1120 RT (avg load 590RT)

Water Type
Portable Water

Savings (14h/6d)

- Energy: 7.1%
Est. Annual Energy Savings @ 590 RT
113,704kWh = 46.45 Ton CO2
- Blow-down water: 81.4% (40 COC)
Est. Annual Water Savings
1,846 m³
- Zero chemical discharge

• Already Green Mark Platinum

• Chemical dosing, auto-tubing shut off

As part of BCA's Super Low Energy Building Challenge, our technology was deployed and results tracked and scrutinised by BCA for 14 months at Keppel back in 2018.

Similar results can be seen in our 3M, UOB, Pokka sites in Singapore.

For more information, please contact:

Deston Plastics Pte Ltd

Mr. LIM Wei Yang

M +65 9295 0752

E weiyang.lim@deston.com.sg hello@deston.com.sg

W www.deston.com.sg

Upgrade your Manufacturing Capabilities with Industry 4.0 today!



Are you ready for new opportunities through Industry 4.0?

The Industry 4.0 Human Capital Initiative (IHCI) Programme is designed to help manufacturing companies in Singapore to understand, implement and scale Industry 4.0 successfully through an experiential triple-pronged approach which includes Business, Technology and Organisation!

An Initiative by Supported by



Anchor Partners

IHCI Programme Structure



Hear from our minister:



"By adopting Industry 4.0 solutions, the company (Souperfoods) was able to scale up its operations and improve productivity."

Minister for Manpower & Second Minister for Trade and Industry,
Dr Tan See Leng

Source: <https://www.facebook.com/DrTanSeeLeng>

Minister Tan interacting with Souperfood's Managing Director, Mr Andrew Chan, to learn how technology adoption has improved work

Our Alumni:



"Once we had data (from IOT solution), we started to recognise lost time. We were able to track the standard vs actual (process duration) and from that data analysis, it prompted us to think about the improvement projects we want to do and that is exactly where we are focused right now."

Manufacturing Director, Ms. Hsieh Min Zong

ASM has participated in IHCI Cohort 3 where they piloted an IoT solution that provides visibility on process duration across various job steps, which then allowed management to drive improvement in performance and optimise production lead time.

Pricing Fee and Available Subsidies for the IHCI Enabler Programme

Over \$60,000 government subsidy to help you in your business transformation

Subsidy 1

WSG absorbs 90% (SME) or 70% (non-SME) of the original programme fee \$63,250

Subsidy 2

SSG SkillsFuture Enterprise Credit (SFEC) - S\$10,000 credit to cover up to 90% out-of-pocket expenses

SMEs are defined as:

- Registered and operating in Singapore;
- Have minimum 30% local shareholding; AND
- Company's Group annual sales turnover not more than S\$100 million; OR
- Company's Group employment size not more than 200 workers



Disclaimer: Final costs may differ depending on remaining value of subsidy

Scan the QR code to register your interest for our next cohort!

Cohort 6 (Feb 2022)
Cohort 7 (May 2022)



Explore our self-help portal to discover Industry 4.0 application guides:



Strategic Partners



Other Alumni Made Possible with



SEMICONDUCTOR TRADEWINDS

November / December 2021

What a stellar year 2021 has been for the semiconductor industry. In 2021, the industry has been on a turbo charged journey to new heights driven by the pandemic. The almost continuous month-on-month growth throughout the year has no end in sight in the short term. According to SIA, 2021 global semiconductor sales are forecast to exceed US\$550 billion, up almost 26% compared to 2020, and the highest growth seen since 2010.

In IC Insights rankings, Samsung retook the number one semiconductor company position from Intel in Q2 based on sales, and is expected to be ranked number one semiconductor company for 2021. 17 companies are forecast to have semiconductor sales in excess of S\$10 billion in 2021, with 16 of them

registering double digit year-on-year growth ranging from 17-65%. Only Intel in second position is expected to show a decline in 2021, by just 1%.

Foundries and OSATs also had a record year, with revenue from the top 10 foundries expected to exceed US\$100 billion for the first time, an increase

of 20% year-on-year according to Trendforce. TSMC is predicting that its revenue in 2021 will grow 24% to around US\$57 billion. The OSAT market is doing similarly well, with revenue of the top 10 OSATs reaching US\$8.89 billion in Q3 2021, a 31.6% year-on-year increase, according to TrendForce.

Equipment sales are also growing month-on-month. Based on data from SEMI, equipment sales for 2021 are expected to reach a record US\$103 billion, up 45% compared 2020, driven by Fabs and OSATs expanding capacity.



No matter where you are in the semiconductor industry, you would have probably been impacted to some extent by the global supply shortage, and had a stressful but exciting year. Be it in Fabs and OSATs where you faced material shortages while being pushed to increase output to maximum levels despite manpower issues caused by COVID. Similarly challenging if you are an IC or electronic goods supplier, you would have spent the year continually pushing to ensure you get adequate supply of chips at the right time to keep factories going and customers happy. The automotive segment has also been particularly hard hit and is forecast to have lost an estimated US\$200 billion in sales last year due to lost production. Temporary production line shutdowns caused by chip shortages have occurred at all major car manufacturers throughout the year. Other segments



have been similarly affected, ranging from smartphone manufacturers to equipment manufacturers.

Even if you can get supplies of semiconductor devices, material and chip prices have been continually increasing in 2021, and on top of that, arranging shipments has been a challenge as logistics shortages have meant delays and increased shipping costs.

NEW FAB ACTIVITY

The global shortage led many companies to announce plans to build new Fabs and facilities. SEMI estimated that 30 new Fabs will start to be built by the end of 2022, with production expected to start by the end of 2023 or in 2024 - more may be announced. China and Taiwan lead the growth in new Fabs followed closely by the US, where TSMC, Intel and Samsung have all announced new Fabs to be built. 23 out of the 30 new Fabs will be 300mm facilities - of

which 15 will be foundries. Singapore was not left out with GlobalFoundries starting construction on a new 300mm Fab at its Woodlands campus.

MERGERS AND ACQUISITIONS

While 2020 was a record year for semiconductor merger and acquisitions, with deals worth US\$118 billion, 2021 had been much quieter with acquisitions valued only around US\$22 billion. This may be in part due to difficulty in getting regulatory approval for acquisitions in the current climate, with two of the mega deals from 2020 still pending approval. NVIDIA's US\$40 billion bid for ARM is facing additional scrutiny by UK, Europe, US and China regulators, while AMD's US\$35 billion acquisition of Xilinx is still pending Chinese approval. Two large deals from 2020 that did receive approval from China were Analog Devices' US\$21 billion acquisition of Maxim - which closed in August - and

SK Hynix's US\$9 billion acquisition of Intel's NAND business. In 2021 the biggest deals were II-VI acquiring Coherent for US\$7 billion after a three-way bidding battle, and Renesas agreeing to acquire Dialog for US\$5.7 billion in February and closing the deal on 30 August. GlobalFoundries also went IPO in October, with its owner Mubadala raising US\$2.5 billion while retaining an 89% stake, valuing the company at US\$25 billion.

FORECAST

Looking ahead to 2022, the current boom in semiconductors is expected to continue. The current global chip shortage is expected to continue into 2022, with foundry and OSAT capacity reported to be fully booked this year. Global semiconductor sales are expected to increase a further 9% in 2022 to exceed US\$600 billion, according to SIA. Trendforce is predicting that Foundry revenue is also expected to grow in 2022 and reach around US\$118 billion, a 13% increase from 2021's record revenue. Equipment sales are also expected to continue to increase a further 11% in 2022 to reach US\$114 billion.

All over, the outlook is looking very rosy for the semiconductor industry - enjoy it, it's a nice problem to have.



CONTRIBUTED BY

MARK DYSON

Head of Global Subcon Manufacturing of Osram Optoelectronics

Making Possible a Better Future through 30 years in Southeast Asia



Applied Materials South East Asia is one of the largest employers and contributors to the output of Singapore's semiconductor equipment industry. Those in the industry know the company as the engineering prowess behind some of today's most advanced chips.

In 2021, Applied celebrated 30 years of growth, milestones and innovation in Singapore.

Over the years, Applied has partnered with A*STAR and other research institutes to build up a strong R&D footprint in Singapore, with three R&D labs that conduct research and product development for new materials, advanced packaging and new markets. Today, some of Applied's most sophisticated technologies are designed and manufactured right here in Singapore, and drive innovations in the global semiconductor industry.

Applied Materials' economic and community contribution to Singapore was recognised in 2019, when it was conferred the Economic Development Board's Distinguished Partner in Progress award.

Mr Brian Tan, Applied Materials' regional president, said more is to come from the company in the years ahead, as semiconductors form the bedrock and driving force behind digitalization.

"Everything is getting smarter – from our phones to our cars to our homes – and this is driving further demand for current and next-generation semiconductors," he noted. "We are only at the beginning of major technology and market inflections that will play out over the next decade."

"At Applied Materials South East Asia, we remain committed to Singapore and are continuing to invest in expanding our capacity and footprint in manufacturing and R&D here," Mr Tan noted.

"We look forward to translating more technologies into real world products and commercial applications, and partnering our customers to solve their toughest challenges and enable their success."

Making Possible a Better Future with the 1X-100X-10,000X Sustainability Roadmap

Just as important as its role in the semiconductor industry is Applied Materials' commitment to corporate responsibility, as reflected in the company's vision to Make Possible® a Better Future.

Throughout its global operations, Applied considers environmental impact as part of every significant decision it makes. Its long-term sustainability framework optimizes how Applied runs its business (1X), how it multiplies its impact by working with customers and suppliers (100X), and how technology can be used to advance sustainability on a global scale (10,000X).

Applied views issues like climate change and water use as opportunities and drivers for change. The company has aligned around a bold 3x30 goal, which calls for Applied's manufacturing systems to use 30% less energy and 30% fewer chemicals while increasing output efficiency 30% by 2030.

Applied is a strong partner to the industry ecosystem to create innovative solutions and advance sustainability initiatives in Singapore. Its technology improves efficiencies, reduces emissions and lowers energy consumption for chipmakers. Together with industry partners and customers, Applied is creating innovation that drives sustainability transformation in the semiconductor industry.

1X
For our business

100X
For the industry

10,000X
For the world



In Singapore, Applied also gives back to the local community to promote a more sustainable future. As part of its 30th Anniversary celebrations, the company committed to plant 500 trees over the next five years in support of the Singapore OneMillionTrees movement.

Applied Materials South East Asia is also a proud donor to the Singapore Botanic Gardens Seed Bank, a conservation, research, and education facility. The donation supports the Seed Bank's research into the optimization of seed storage to help safeguard plant biodiversity in Southeast Asia.

To the next 30 years

For Mr Lee Guan Tay, a director for field service, it has been 20 amazing years with the company – his first and only employer.

"Over the last two decades, I have witnessed the evolution of Applied Materials South East Asia from a small sales and service organisation to having significant manufacturing and R&D footprint here" he said.

"All of this is made possible by the people on the team," he added. "Glad to see colleagues becoming friends, friends become life-long friends, life-long friends becoming family friends. I am fortunate to be part of the family."



<p>Opened modest sales and service office in Singapore</p> <p>1991</p>	<p>Opened the Singapore Operations Centre - Applied's first facility in Asia for manufacturing advanced semiconductor equipment and the largest manufacturing facility outside of the U.S.</p> <p>2010</p>	<p>Opened the Advanced Materials Corporate Lab with NUS to accelerate discovery and commercialisation of new materials</p> <p>2018</p>	<p>Applied Materials South East Asia turns 30! Extended research collaboration with A*STAR's IME on Applied's Advanced Packaging Development Centre</p> <p>2021</p>
---	---	---	--

Applied Materials South East Asia's Key Milestones

<p>Opened offices in Kulim and Kuching, Malaysia</p> <p>2000</p>	<p>Opened office in Clark, Philippines</p> <p>2008</p>	<p>Opened Applied's Advanced Packaging Development Centre for R&D of 3D chip packaging</p> <p>2011</p>	<p>Conferred the Distinguished Partner in Progress Award by Economic Development Board for significant economic and community contributions to Singapore</p> <p>2019</p>
---	---	---	---

For more information, please visit www.appliedmaterials.com





Industrial Transformation ASIA-PACIFIC (ITAP) 2021

Setting the foundation for a future of hybrid events at the Singapore EXPO.

4th edition of the Industrial Transformation ASIA-PACIFIC (ITAP) 2021, organised by Constellar and our International Partner, Deutsche Messe, successfully concluded on 24 November 2021, attracted over 11,000 attendees physically and digitally from more than 70 countries across 3 days.

ITAP 2021 was held in a hybrid format, with a total of 143 exhibitors from 11 countries, 5 national pavilions from Singapore, China, Germany, Indonesia, and Malaysia, and 3 industry-led pavilions from the NAMIC Industry Pavilion, the Smart Logistics Pavilion by CargoNOW and the MAGIC Pavilion.

The exhibition was divided into four categories:

- Additive Manufacturing, featured Integrated industrial 3D printing solutions
- Digital Factory, featured Integrated processes and IT solutions
- Industrial Automation, featured factory and processes automation and System solutions
- Intralogistics, featured intelligent logistics and supply chain management solutions

Guest-of-Honour, Deputy Prime Minister Mr Heng Swee Keat, delivered an opening address at ITAP 2021 on the first day, joined by German

Ambassador to Singapore His Excellency Mr Norbert Riedel and ITAP's international partner Deutsche Messe's Chairman of the Managing Board, Dr Jochen Köckler. They gave their welcome remarks in-person and virtually 'live', respectively.

The event also facilitated over 500 business meetings and six signing of memoranda of understanding by industry players across 3-day.



AN OPPORTUNITY TO MEET INDUSTRY COUNTERPARTS FACE-TO-FACE

The ITAP 2021 physical exhibition was the largest in-person exhibition in Singapore since the pandemic started, hosting over 3,600 physical attendees at Singapore EXPO. In an industry where face-to-face interaction remains the preferred mode of engagement, ITAP 2021 worked in collaboration with the local authority as a pilot event of

the Vaccinated-Differentiated Safe Management Measures + Test (VDS + Test) protocols, to bring in local and regional attendees physically, providing much needed face-to-face engagements between exhibitors and delegates in a safe environment.



Attendees of the physical event got the chance to visit exhibitions and activities such as the Gateway to Industry 4.0, the Industry 4.0 Experience Zone, open mic presentations (Industry Connect Live Talks) by the Singapore Governments Pavilion, and over 100 other I4.0 physical showcases.

GATEWAY TO INDUSTRY 4.0 POWERED BY TÜV SÜD

As an Introduction to getting started in their business transformation, all attendees were welcomed by an immersive gallery on the evolution of Industry 4.0 and showcases of successful deployments, enabling technologies and actual benefits. Powered by TÜV SÜD, the Gateway to I4.0 showcase allowed attendees to learn from the transformative outcomes of practical I4.0 applications demonstrating real value and benefits.



I4.0 EXPERIENCE ZONE POWERED BY SINGAPORE POLYTECHNIC (SP)

From immersive Augmented Reality (AR) to complementary clinic sessions, the I4.0 Experience Zone powered by Singapore Polytechnic (SP) has showcased a myriad of end-to-end solutioning and training capabilities to accelerate digital transformation at any stage. This specially designed zone has featured 6 exclusively sections, each dedicated to showcasing the latest technologies in enabling i4.0 and workforce transformations. The attendees get to observe the vast and diverse possibilities that 5G and Artificial Intelligence of Things (AIoT) technologies bring to Advanced Manufacturing and I4.0 through Augmented Reality technology. Attendees were also given the chance to learn from industry use cases and watch live demos of remote field assistance and robotic arms.



A REFRESHED DIGITAL EXPERIENCE FOR CONTENT AND PARTNERSHIPS

ITAP 2021 also engaged attendees from over 70 countries through a specially designed digital platform - ITAP CONNECTED. Online attendees had access to comprehensive exhibition e-showcase and networking opportunities through AI-powered business matching. The platform also featured over 150 content sessions by more than 120 local and international speakers at

the Industry Transformation Forum (ITF), Future of Manufacturing (FoM) Summit and Industry Roundtables, Standards Forum, and Digital Sandbox. These conferences discussed the latest manufacturing technologies, key industry developments, strategic regional developments, and regional government initiatives on I4.0.

For the first time, ITAP 2021 partnered with the region's leading supply chain trade events - LogiSYM 2021 and CargoNOW 2021 - to harness cross-industry synergies. This collaboration drove knowledge sharing, capability and opportunity in Smart Logistics and Supply Chain Management Solutions.

ITAP 2021 is strongly supported by various government agencies, including Singapore's Agency for Science, Technology and Research (A*STAR), Economic Development Board (EDB), Enterprise Singapore (ESG), JTC Corporation (JTC), SkillsFuture Singapore (SSG) and the Singapore Tourism Board (STB) along with their regional counterparts as well as global industry leaders and key players in the region's business ecosystem.

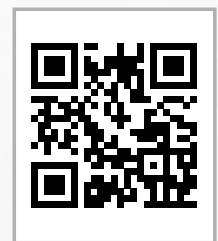

Scan here to join our mailing list for latest ITAP's event update!

See you at ITAP 2022 on 18-20 October.

CONTRIBUTED BY



Drive semiconductor breakthroughs *that define the next generation.*

At Lam Research, we relentlessly pursue innovation that pushes the boundaries of technical limitations, creating solutions that enable chipmakers to power progress. Our programs allow you to develop your career, build on your educational accomplishments, and play a key role in bringing to market innovation technology and business solutions in countries around the world.

INTERNSHIPS

Get hands-on business experience that complements your academic studies and prepares you for real-world situations.

NEW COLLEGE GRADUATES (NCGs)

We move recent graduates quickly into impactful roles and provide training that helps develop the skills needed to become future leaders.



Explore our programs at [lamresearch.com](https://www.lamresearch.com)

Connect with us



NTU Prepares Talents for Industry

Advanced scientific instrumentation is an incubator of innovation in many fields, including the manufacturing industry. Advances in precision scientific instrumentation are greatly enhancing the efficiency of information processing and storage technology. In Singapore, a budget of S\$25 billion in the Research, Innovation, and Enterprise 2025 plan (RIE2025) was allocated for R&D with a focus on industry-oriented development projects. With the booming need of semiconductor chips and other semiconductor-based products, demand for talent in this field is increasing.

Embark on the first Master's Programme

Nanyang Technological University, Singapore (NTU Singapore) now offers a Master of Science (MSc) in Precision Scientific Instrumentation programme, hosted by the School of Physical and Mathematical Sciences. This postgraduate coursework-based programme is designed to fill industrial gaps through training young talent and working professionals. Its curriculum covers the principles and operation of advanced technical instrumentation used in the physical sciences and high-tech manufacturing, incorporating coursework from multiple scientific and engineering



disciplines including solid-state physics, microelectronics, optoelectronics, and materials science. Emphasis is placed on understanding the fundamental physical principles behind modern scientific instrumentation.

Quantitative measurements are performed in every area of science, engineering and technology. Modern high-tech enterprises rely on a variety of precision scientific instruments for the design, development, and manufacturing of new products, as well as the control, calibration and diagnosis of physical processes. The MSc in Precision Scientific Instrumentation programme offers an in-depth exploration of precision scientific instrumentation used in high-tech industries, including semiconductor technology, nanotechnology, spintronics and optoelectronics. The coursework emphasises analytical and troubleshooting skills that are relevant to industry, with intensive hands-on exercises guided by subject matter experts. Students will gain exposure to state-of-the-art facilities and projects in the NTU research labs.

The programme aims to attract fresh graduates and working adults who have a tertiary education background in science and engineering. Besides local graduates, the programme aims to draw quality students from regional Institutions, such as those from Southeast Asia region. Thus far, there are few equivalent programmes in Asia providing a similar balance of physics analysis and applied skill training. The programme is particularly keen to attract established industry professionals who wish to embark on a formal course of study to update and expand their expertise.

For more information, visit <https://www.ntu.edu.sg/spms/about-us/physics/grad/msc-in-precision-scientific-instrumentation>

Reshaping Your Supply Chain with Additive Manufacturing Driving Strategic Operations

Additive manufacturing (AM), or more commonly known as 3D printing, is evermore proving its value to industrial clients when managing spare parts. These manufacturing technologies are no longer constrained to the innovation sandbox and are permeating into companies' real lives.

Let's get one thing out of the way: additive manufacturing is a validated technology to manufacture polymer, metal, or ceramic parts; 3D printing is adapted to printing complex parts, critical parts, but also simple parts with

costly supply chain drivers (high mix/low volume, obsolescence, and just in time to name a few).

If anything, in the last two years, corresponding supply chain disruptions and CO2 footprint assessment have proven a fertile ground to accelerate AM adoption for parts operations.

In order to transform AM into a strategic lever, industrial companies need to be able to assess, upfront and at scale, the potential value that these technologies can create. The apparently simple assessment process to:

1. Identify
2. Build Bill of Materials adapted to AM; and
3. Print

becomes cumbersome and unaffordable the moment companies want to scale this AM adoption.

This is why Spare Parts 3D has developed DigiPART, aimed at reducing the cost of identification and engineering, thus lowering the entry barrier to adopt AM.

HOW DIGIPART WORKS...

1 IDENTIFY - Assess what to print.

DigiPART IDENTIFY allows our clients, even with partial information (e.g., missing 3D files, or 2Ds) to automate the technical and economical assessment of AM for spare parts. With our client's data and our field-proven algorithm, we automate the analytical process:

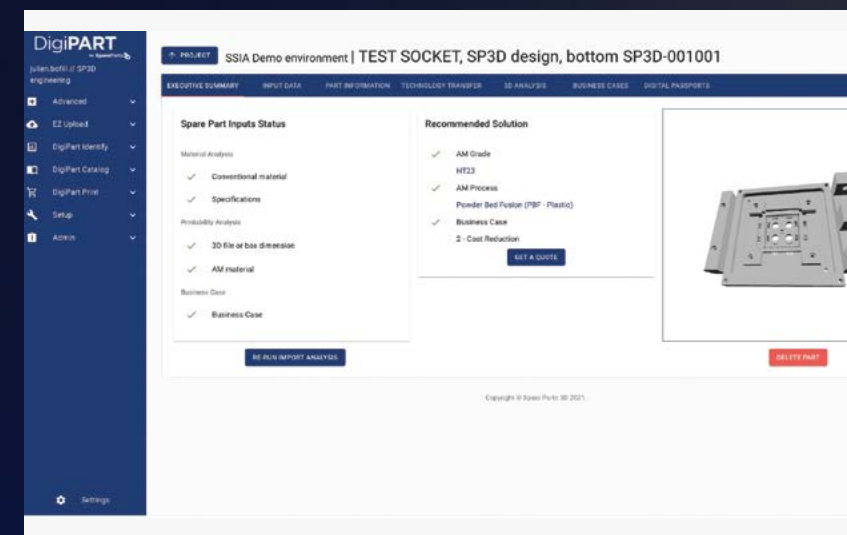

from data enhancement (with proxies if data is missing), defining the functional specifications blueprint for each part, matching the AM material and process, calculating the business cases, and finally to defining a road map of adoption.

2 CATALOG - create Digital Passport.

Once clients have identified the part on which they want to work, they compile the necessary documents to print right first time (2D-3D model/inspection plan/3rd party, etc.) and freeze those with DigiPART CATALOG

in a digital passport that can be used to request a quote and for traceability purpose.

3 PRINT - Find the right supplier.

With DigiPART PRINT, Spare Parts 3D will help identify suppliers in line with your expectations.

This three-step journey is **automated** (leveraging machine learning and extensive databases), **reliable** (field-proven methodology in different industries) and completely **transparent** (from data input to

supplier selection). DigiPART is also set up so that both engineering and supply chain stakeholders can decide what's best for the company.

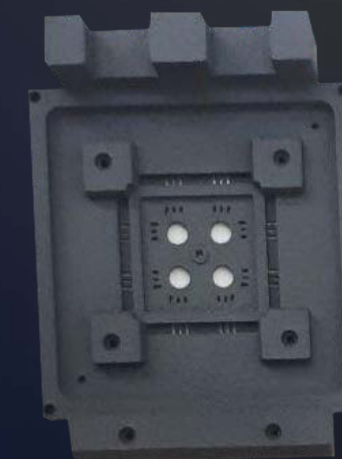

Test sockets 3D-printed

Prepare for the next supply chain "hiccup":

- Anticipate... IDENTIFY at scale
- Be ready for AM... build your digital CATALOG to execute when needed for print

Find out more at www.spare-parts-3d.com or contact us at contact@sp3d.co for a demo.

DigiPART a 3-in-1 SaaS solution to get your inventories ready for AM

DigiPART IDENTIFY

- Identify the parts suitable to be 3D printed
- Find AM solutions and estimate your ROI

Adoption matrix prioritizing parts with clear priority

DigiPART CATALOG

- Reverse-engineer parts on demand from 2D drawing or directly a part
- Build inspection & qualification plans for production

Here is a short list of the parts your order the most:

Digital Passport: qualified data package ready for 3D printing

DigiPART PRINT

- Assess design optimization potential, simulation process & costs
- Connect with our 800 global suppliers and print

E-procurement system to print on-demand

"Spare Parts 3D's proprietary method is **10 TIMES CHEAPER AND 50 TIMES FASTER** than doing it manually without any loss of accuracy." - HP/Spare Parts 3D joint study

Reduced production time from 18 weeks to 1 week

Create your own project

DigiPART

olivier.mathey@sp3d.co // Demo Business Cases

- Advanced
- EZ Upload
- DigiPart Identify
- DigiPart Catalog
- DigiPart Print
- Setup
- Admin

BACK TO PROJECTS

Your project name: SSIA - Voice Magazine

DOWNLOAD IMPORT TEMPLATE HERE

Click or Drop your BOM (excel, xlsx format)

Click or Drop your attached files here

Up to 6 files - Max file size: 25 MB

Up to 1000 files - Max file size: 25 MB



CONTRIBUTED BY

OLIVIER MATHEY

Vice President

Sales - Middle East Asia

[linkedin.com/in/oliviermathey](https://www.linkedin.com/in/oliviermathey)

SpareParts 3D

Struggling to keep the media temperature consistent in your chiller hose?

Learn more about Swagelok hoses and insulation options.



Scan the QR code to visit our website or contact us at inquire@swagelok.com.sg or at +65 6367 0688.



On-Chip Sensor Solution for Indoor Air Quality (IAQ) Monitoring

Indoor air quality (IAQ) receives increasing attention due to its direct impact on overall human health and work efficiency since humans spend more than 80 per cent of their routine time indoors. If proper ventilation arrangements are missing in building structures, the IAQ decreases, and the environment becomes unhealthy for the occupants. Furthermore, the continued growth of the world population has posed energy consumption and environmental challenges for us. Designing a smart building by integrating all infrastructure and utilising intelligent devices for monitoring and control is expected to be an effective approach to improve IAQ in an energy efficient way.

In particular, high carbon dioxide (CO₂) levels compromise human health and productivity. Consequently, smart ventilation systems in modern commercial and residential buildings deploy CO₂ sensors to assist ventilation regulation in the most energy-efficient and human-friendly way. With this growing trend, as one of the key components to build IAQ monitoring networks, sensors are in demand for miniaturisation, cost-effectiveness, low power consumption and outstanding sensitivity and selectivity.



To address this demand, the Institute of Microelectronics (IME) has developed an on-chip nondispersive infrared (NDIR) sensor solution, enabling room temperature CO₂ detection with high sensitivity, low

drift, and low power consumption. Infrared gas sensors hold great promise in terms of low cross-sensitivity, low drift, high selectivity and sensitivity, plus precise and stable long-term operation. They can directly sense the resonance frequency of the bonds representing the targeted gas. Benefitting from advanced MEMS fabrication process and packaging capabilities, the IME team was able to develop this on-chip NDIR gas sensor solution. The CO₂ sensor features a detection range up to 5,000 ppm, with a sensitivity of 30 ppm, and a complete module size of only 1 x 2 x 2 cm³ including communication and processing.

IME plans to use the developed sensor technology to build a multi-gas detection platform. For example, the team has also developed a sensor that is more applicable for industry use with an accuracy of $\pm 0.1\%$ for monitoring and reducing emissions. With further device and system design improvements, the sensor platform will provide cost and energy-effective solutions for many applications in the near future.

ENVIRONMENTAL GAS SENSOR PROTOTYPES



Indoor CO₂ Sensor Prototype

- Application: Indoor CO₂ Sensing 0 to 5000 ppm
- Status: Demonstrated with different air mixtures
- TRL: 4 - Technology validated in lab and indoor environment

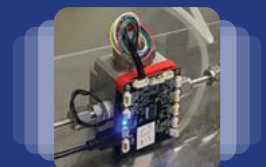

Industrial CO₂ Sensor Prototype

- Application: Industrial and emissions CO₂ Sensing 0 to 100% Concentration, High Pressures
- Status: Demonstrated with different CO₂ gas concentrations
- TRL: 4 - Technology validated in lab

CONTRIBUTED BY





**SYSTEMS ON SILICON
MANUFACTURING COMPANY**



IMPROVING THE LIVES WE TOUCH

With Every Silicon Chip We Make

SSMC employees focus in the creation of technologies that can change the world. We strive to be the world leading source of automotive quality semiconductor wafers and encourage talented individuals to come join our team.

Scan to Start a Virtual Tour



APPLY TODAY AT WWW.SSMC.COM/JOINUS



SSMC OFFICIAL



SYSTEMS ON SILICON MANUFACTURING
COMPANY PTE LTD (SSMC)

Deionized Water Recycling Unit

DWR1722



Ultra-compact DI water recycling unit with extraordinary energy and water conservation

Multi-function ultra-compact DI water recycling unit

The DWR1722 is a DI water recycling unit for dicing saws with functions for DI water production, water temperature adjustment, filtration, and removal of suspended solids such as cutting particles.

Providing environmentally friendly performance

The high recycle rate (99.5% with zero wastewater) exceeds what is possible with conventional recycling units and greatly reduces city water consumption. Since this unit can be installed adjacent to dicing saws, piping can be shortened and water temperature fluctuations as the water runs through the piping can be minimized.

Enabling efficient introduction into your facility

Different from the conventional large scale DI water recycling facilities, this unit can be introduced efficiently in accordance with the number of dicing saws installed. For the DWR1722, the RO unit and other functions have been reclassified as options, for a simplified standard specification.



DWR1722

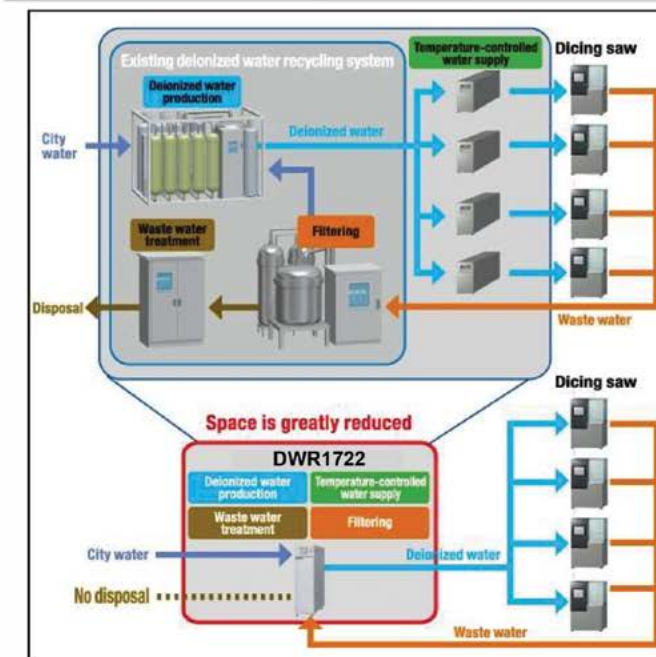

CC Filter

Easy maintenance: The CC Filter and ion exchange resin can be replaced with a one-touch coupler connection.

CC Filter: The DISCO original CC Filter provides both high filtration performance and long life time. Suspended solids filtered out by the CC Filter can be disposed of easily together with the filter.

Easy operation: Operation of the DWR1722 can be linked with a dicing saw (optional). This reduces the load on the operator and the possibility of human error

* Notes: - A separate water supply at a controlled temperature is necessary in order to cool the chiller unit. The DWR1722 can handle two dual spindle dicing saws or four single spindle dicing saws. When producing DI water from city water, an RO film unit (option) is required. For further information please contact your local sales representatives.



DISCO CORPORATION

www.disco.co.jp

Contact :- DHSsales@discosin.com.sg

Nuvoton Technology Corporation (NTC)

Nuvoton Technology Corporation (NTC) was founded to bring innovative semiconductor solutions to the market. A short introduction to our brand name: **NUVOTON 新唐**:

NUVO: similar to French pronunciation “nouveau” (new 新)

TON: similar to Chinese pronunciation “Tang” (唐), as in the Tang Dynasty which had the most impressive inventions and advancements in Chinese history.

Nuvoton Technology Corporation’s expectation for our future – To open up a new world of innovation with pioneering thinking.

NTC was spun-off as a Winbond Electronics affiliate in July 2008 and went public in September 2010 on the Taiwan Stock Exchange (TSE). NTC focuses on the developments of microcontroller, microprocessor, smart homes and cloud security IC, and has strong market share in Industrial, Consumer and Computer markets. NTC spends 25% of its revenue on research and development, introduces more than 30 new products yearly and holds 1137 patents. NTC’s consolidated net revenue reported was NT\$20,668 million*1 in 2020.

In September 2020, Panasonic Semiconductor Solutions Co. Ltd. and its subsidiaries in Japan and Singapore were acquired by NTC and thus expanding its width and depth

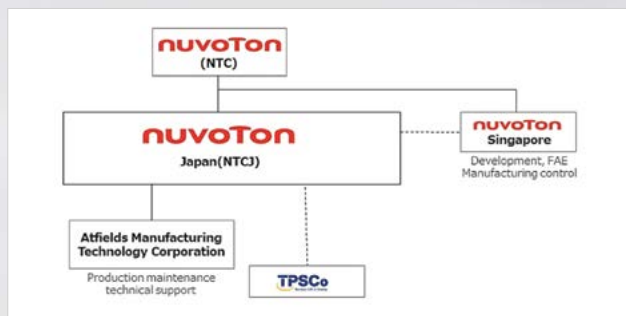

of talents and technologies. Till November 2021, NTC’s consolidated net revenue was NT\$38,063 million*2.

With this acquisition, NTC expanded its business globally with locations around the world.



Two of the focus technology areas are in Spatial Sensing and Battery Sensing - combining technologies of Spatial Sensing and Battery Sensing solutions, and seizing changes in the market environment to provide the best combination of values in the automotive and industrial fields. At the same time, doing our part to contribute to environment protection.



Nuvoton offers a lineup of high performance battery monitoring ICs, including automotive qualified, stackable,



and built-in current sensor. Applications include electric and hybrid electric vehicles (EVs), energy storage systems and e-bikes.

Manufacturers have to ensure safety against hazardous events such as lithium-ion batteries catching fire and emitting fumes. Cruising range per charge of EVs must be extended equivalent to a single fueling of internal combustion engine vehicle. High safety and long cruising range required for battery systems are supported by Nuvoton battery monitoring ICs with safety functions, and enables highly accurate voltage measurement - ultimately contributing to the environment by achieving carbon neutrality.

At Nuvoton Technology Singapore Pte. Ltd. (NTSG), one of our roles is the development of devices and solutions. Currently, the NTSG development team has approximately 50 engineers (with plans for future expansion), working on devices (such as Battery Management IC High Speed Interfaces) and solutions development (Inverter Control MCU, HDMI2.1, HMI, AI, and more), contributing to the focus business areas of Spatial Sensing and Battery Sensing solutions. Our engineers utilize unique SOI semiconductor process and circuit design technologies to develop battery monitoring ICs and solutions, as well as support global customers to design safer and longer lasting battery systems.

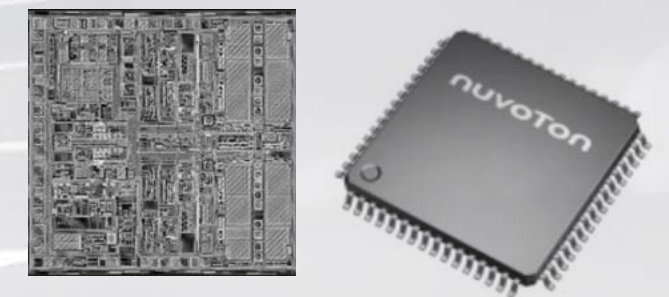

*1: <https://www.nuvoton.com/about-nuvoton/investors/financial-information/monthly-revenue/2020>

*2: <https://www.nuvoton.com/about-nuvoton/investors/financial-information/monthly-revenue/2021>

CONTRIBUTED BY

nuvoTon



While you focus on innovation and driving your business forward with your customers, we focus on efficiently and effectively producing your products in parallel, allowing you to stay ahead of the competition.



Kinergy Corporation Ltd.

www.kinergy.com.sg

CORPORATE RESPONSIBILITY AT AMD

At AMD, we develop semiconductor technology that helps to enable the future. Our high-performance processors power the servers for modern data centers, personal computers, game consoles, industrial devices and more. Our technologies help open possibilities for creators, researchers, inventors and explorers to tackle some of the world's toughest challenges.

That's why we are focused on creating the next generation of products that will positively benefit society and the planet. We aspire to embed environmental stewardship across our business, ensure safe and responsible workplaces in our global supply chain, and promote stronger communities where we live and work.

OUR STRATEGIC FOCUS AREAS:

- > **DIGITAL IMPACT** - We are passionate about designing products that help improve people's lives through high-performance computing solutions spanning healthcare, education, manufacturing, scientific research and other critical needs.
- > **ENVIRONMENTAL STEWARDSHIP** - We are steadfast in our commitments to sustainability by sourcing renewable energy, engaging our employees and suppliers on environmental initiatives, and helping end-users reduce energy use and emissions.
- > **SUPPLY CHAIN RESPONSIBILITY** - We work with our suppliers to deliver high-quality products while also helping ensure that working conditions are safe, workers are treated with respect and manufacturing processes are environmentally responsible.
- > **DIVERSITY, BELONGING AND INCLUSION** - Innovation is at the core of our culture. We encourage and support creative minds from diverse backgrounds to work together in an engaging and open environment.

PURPOSE DRIVEN HIGH-PERFORMANCE COMPUTING

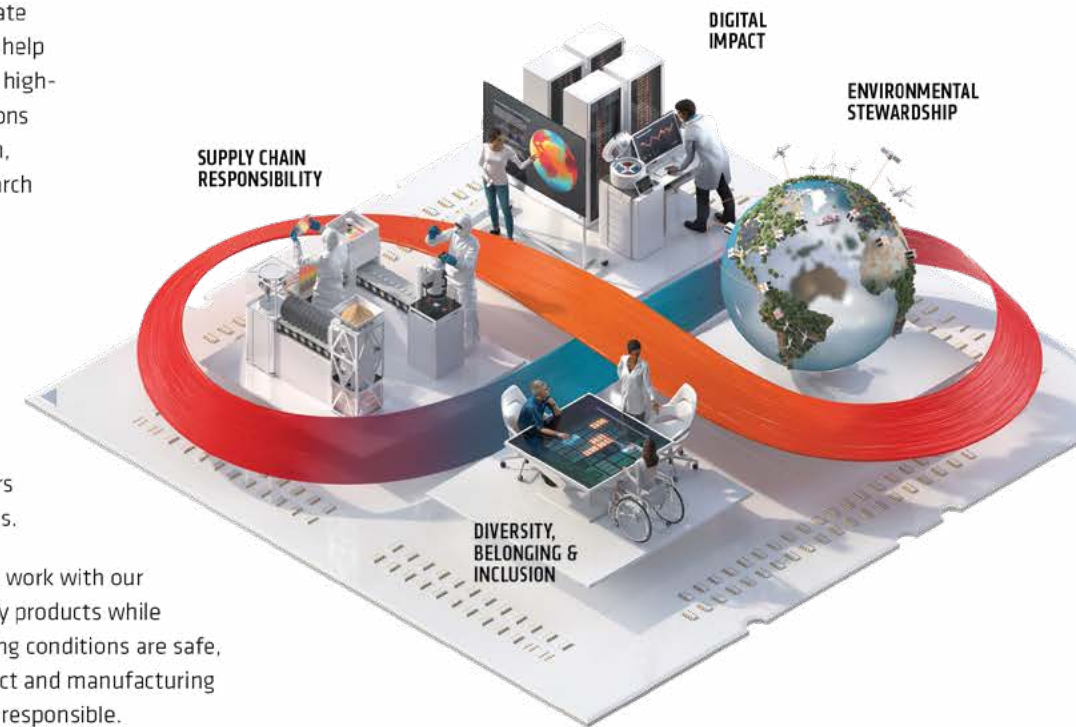

EXTERNAL RECOGNITION:



TO LEARN MORE ABOUT OUR CORPORATE RESPONSIBILITY PROGRAM AND INITIATIVES, PLEASE VISIT: [AMD.COM/CORPORATERESPONSIBILITY/SINGAPORE](https://www.amd.com/corporateresponsibility/singapore)

©2021 Advanced Micro Devices, Inc. All rights reserved. AMD, the AMD Arrow logo, and combinations thereof are trademarks of Advanced Micro Devices, Inc.



Get your game changing ideas
out there.
Create.

REACH OUT

to the Singapore semiconductor ecosystem with VOICE



- >7,000 subscribers
- Visibility on SSIA website & social media
- Also on international digital newsstand Magzter

Explore your next marketing avenue with us



Elevate your content with us
www.redinoxsolutions.com
we@redinoxsolutions.com

REDINOX

✉ secretariat@ssia.org.sg 📞 (+65) 6977 9652